

Procedures

NPR 707 Clipping points

Description

This document describes the procedure for clipping points.

Not what you are looking for? See more [Procedures](#)

Introduction

Point clips are used to secure points in the normal or reverse position. They may also be used to secure expansion joints for wrong running-direction movements.

Securing points

Facing points on running lines must be locked if:

- you cannot be sure that the points will remain in the correct position, or
- there is an instruction at the points to clip and lock them, or
- the points are included in instructions in the controlling signal box.

An SL or XL lock is used to lock point clips. Point clips are kept in signal boxes, traffic huts and various equipment cabinets.

Use standard point clips for standard points. Standard points have a switch blade and stock rail of similar depth. The switch blade is thin.

The standard point clip has a simple hook for the switch blade flange. There are two types of standard point clips:

- J-type point clips
- Conventional point clips.

Procedures

NPR 707 Clipping points

FIGURE 1: Example of fitted standard point clips.

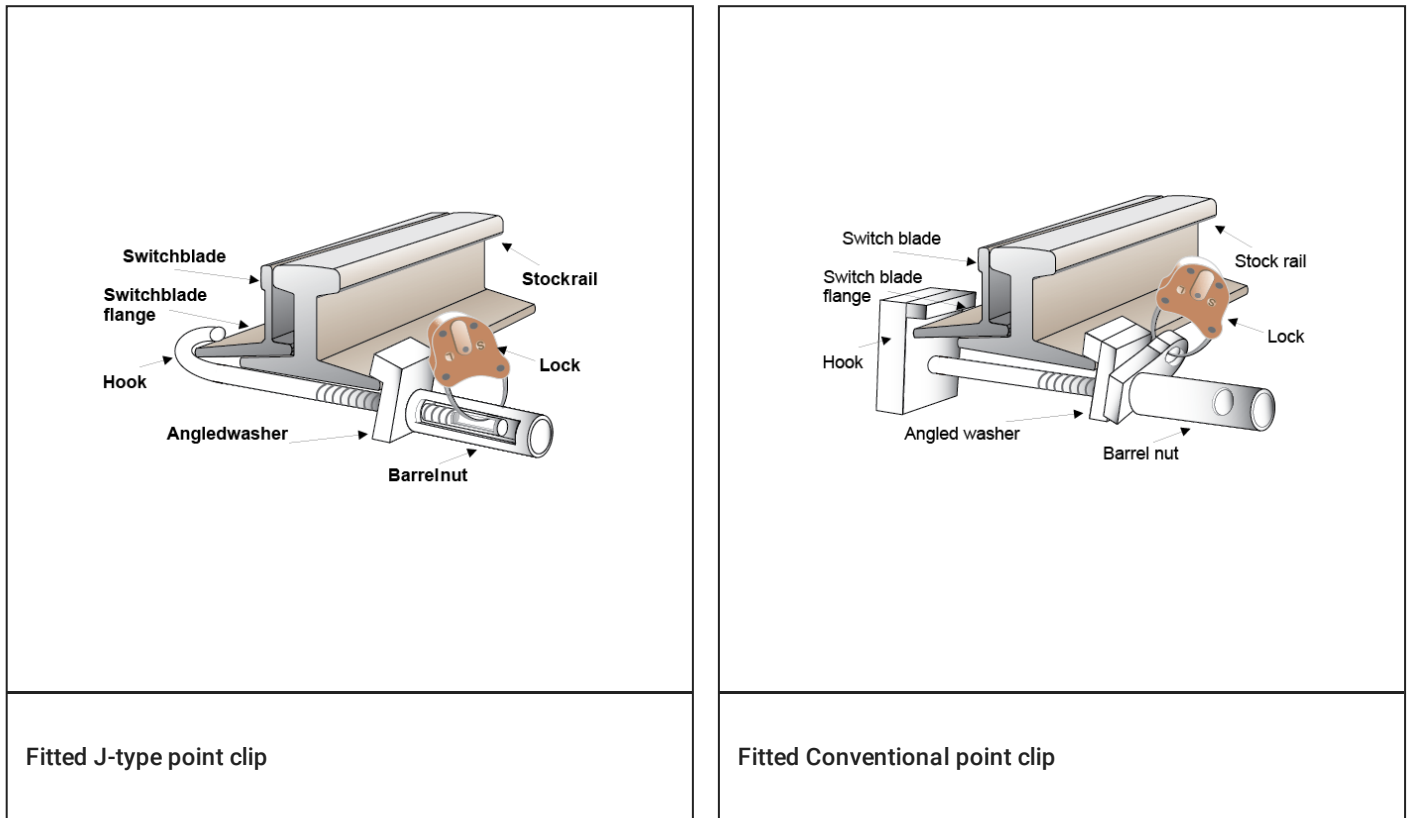

Use tangential point clips for tangential points. Tangential points have a shallower switch blade. The tangential point clip has a stepped hook to suit the shallower switch blade.

Procedures

NPR 707 Clipping points

FIGURE 2: Example of a fitted tangential point clip.

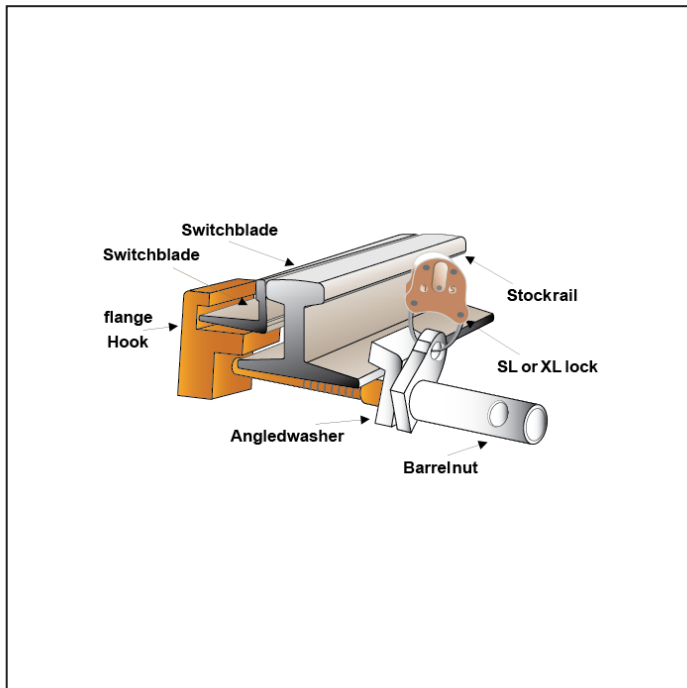

Fitting a points clip

Qualified Worker

- 1 Make sure that you can do the work safely.
- 2 Get authority from the Signaller to clip the points and an assurance the points will not be operated.
- 3 Confirm with the Signaller that the points are in the required position.
- 4 Make sure that the blade is tightly against the stock rail.
- 5 Make sure that you use the correct type of points clip.
- 6 Fit the points clip at the correct position for that set of points, as close as possible to the tapered end of the switch blade.

Procedures

NPR 707 Clipping points

FIGURE 3: Example of point clip fitted as close as possible to tapered end of a switch blade.

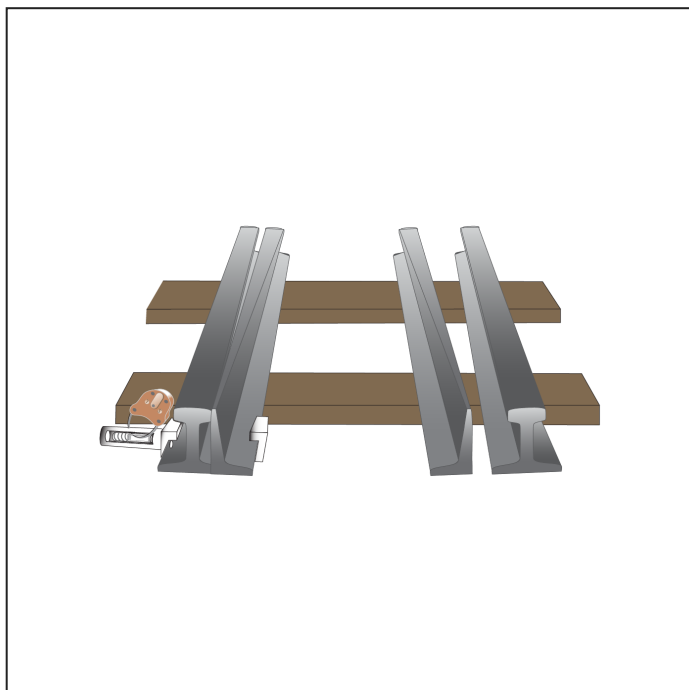

7 Make sure that the points clip is fitted:

- to the underside of the rail, and
- between the sleepers.

i Note

Install the point clip for standard and tangential points so that the barrel nut of the clip is outside the four-foot.

8 Position the jaws of the points clip to the rails and tighten. Hand-tighten the barrel nut, making sure the angled washer is fitted as shown in the Figures.

9 Make sure that the points are properly closed.

10 Lock the points clip using an SL lock or, if authorised, an XL lock.

11 Make sure that the route is correct before allowing rail traffic to travel.