

NSG 604 Indicators and Signs

# Point and catch point indicators

## Description

Not what you are looking for? See more [NSG 604 Indicators and Signs](#)

---

## Point and catch point indicators

Point indicators are used to indicate the position of points. Catch point indicators show the position of catch points.

Point indicators and catch point indicators may be:

- colour light, or
- mechanical.

If the indicator displays:

- a red light, the points are not set
- a white arrow, the points are set for the route indicated by the direction of the arrow.

## NSG 604 Indicators and Signs

# Point and catch point indicators

FIGURE 4: Example of vertical colour light trailing point or catch point indicators.

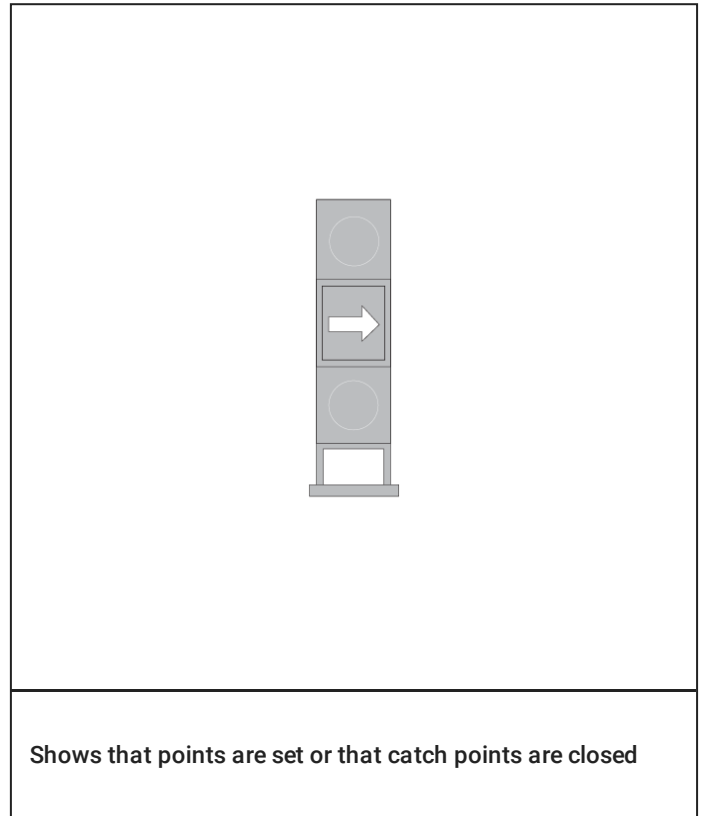
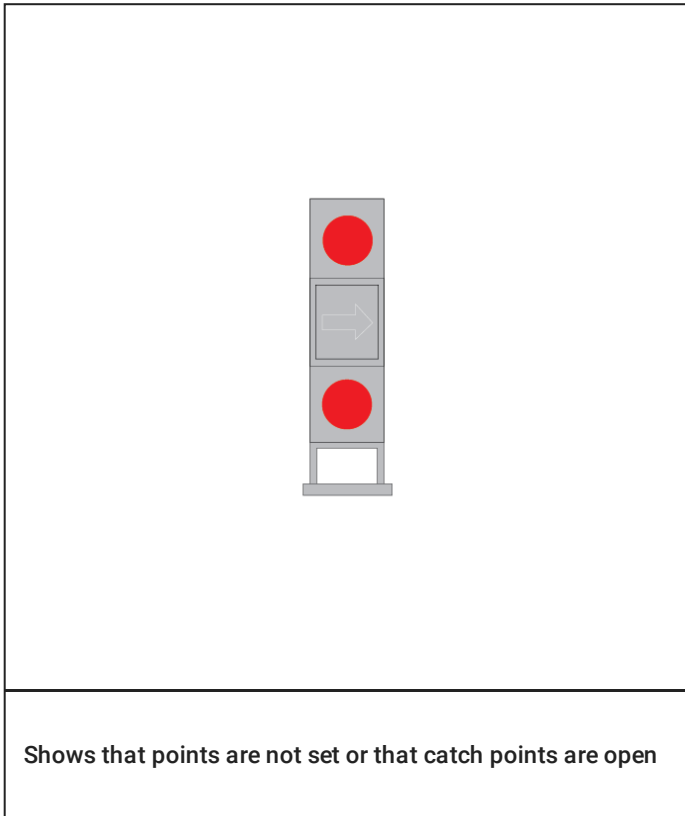

## NSG 604 Indicators and Signs Point and catch point indicators

FIGURE 5: Example of vertical colour light facing point indicators.

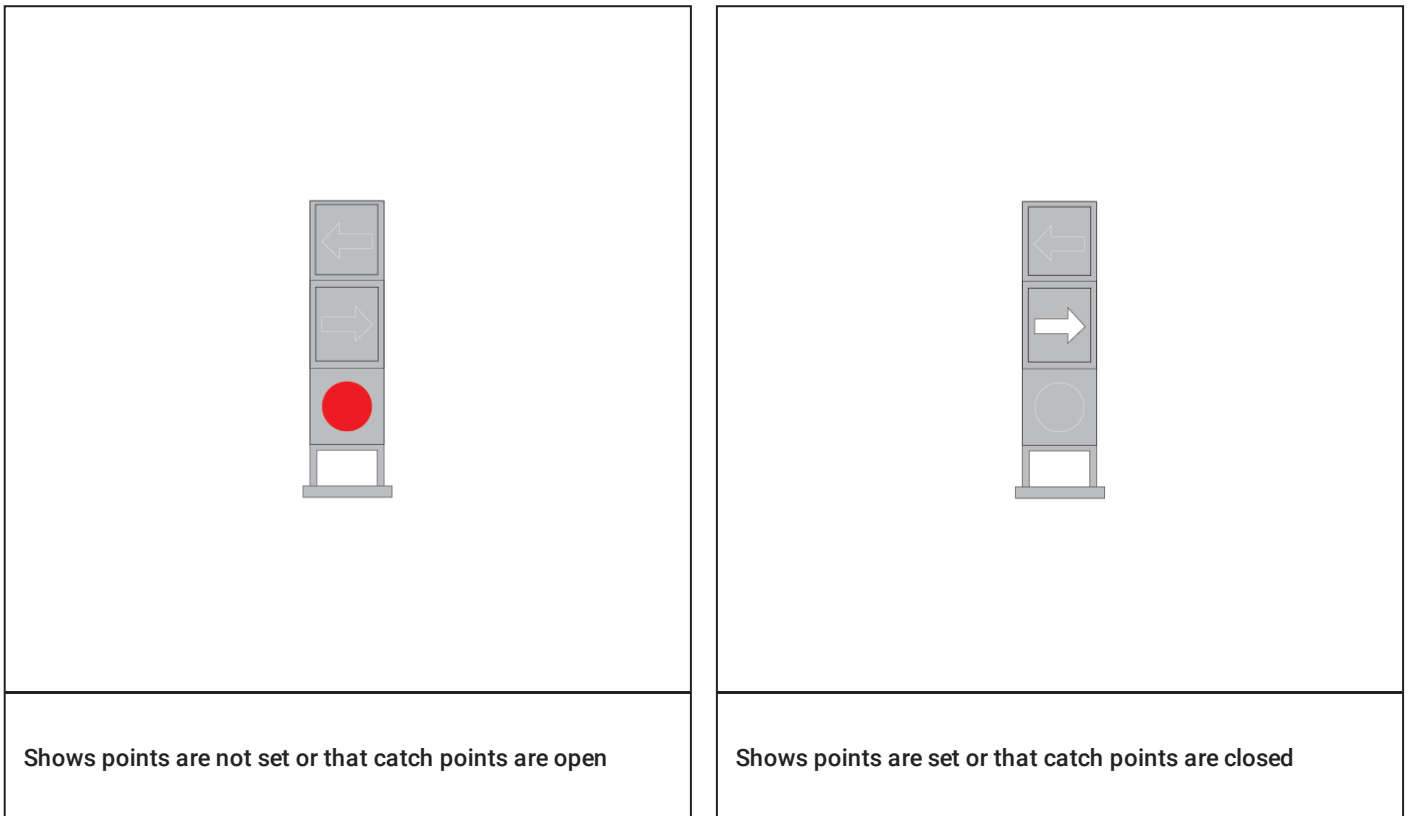

## NSG 604 Indicators and Signs

# Point and catch point indicators

FIGURE 6: Examples of arrow type mechanical catch point indicators.

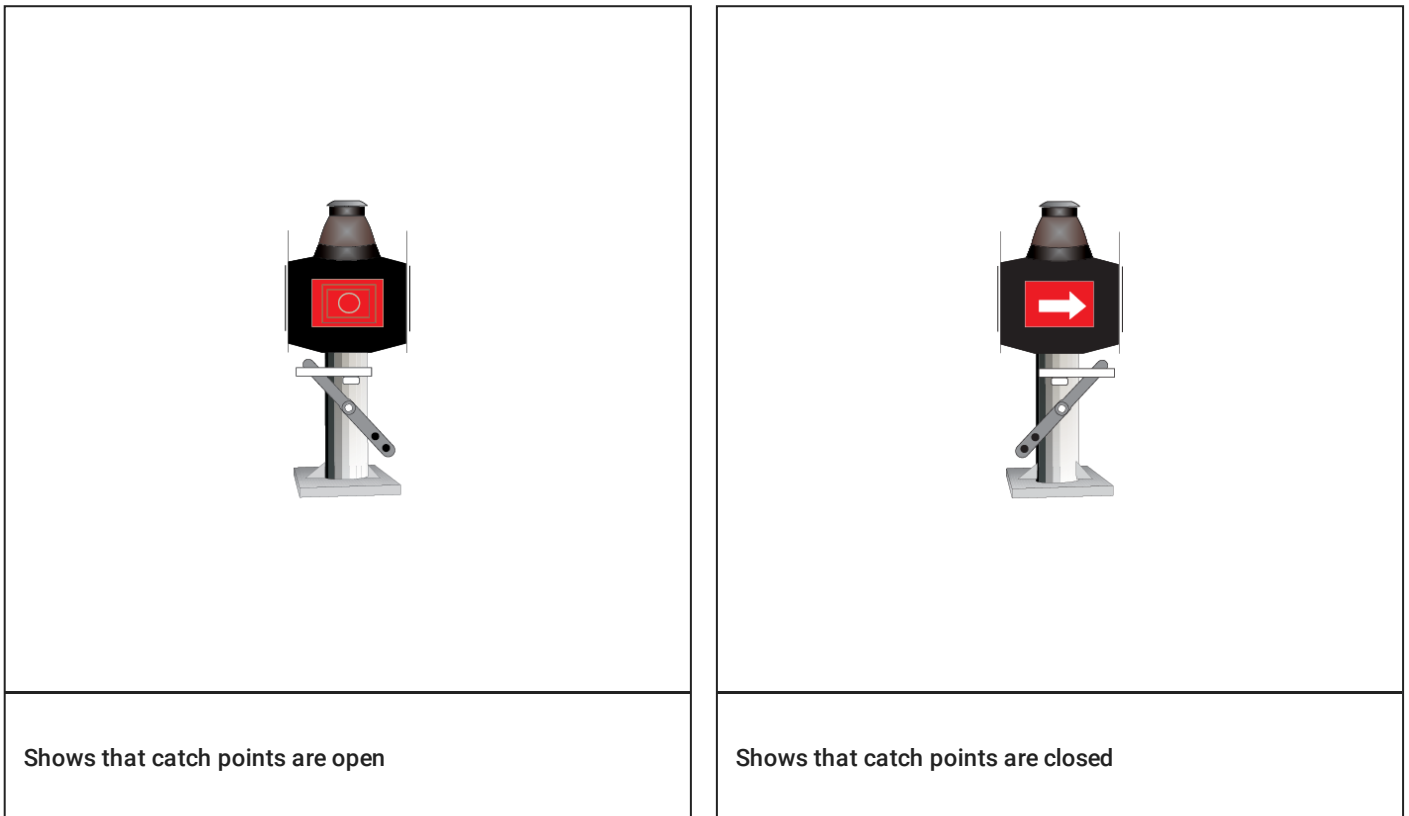

## NSG 604 Indicators and Signs

# Point and catch point indicators

FIGURE 7: Examples of disc type mechanical catch point indicators.

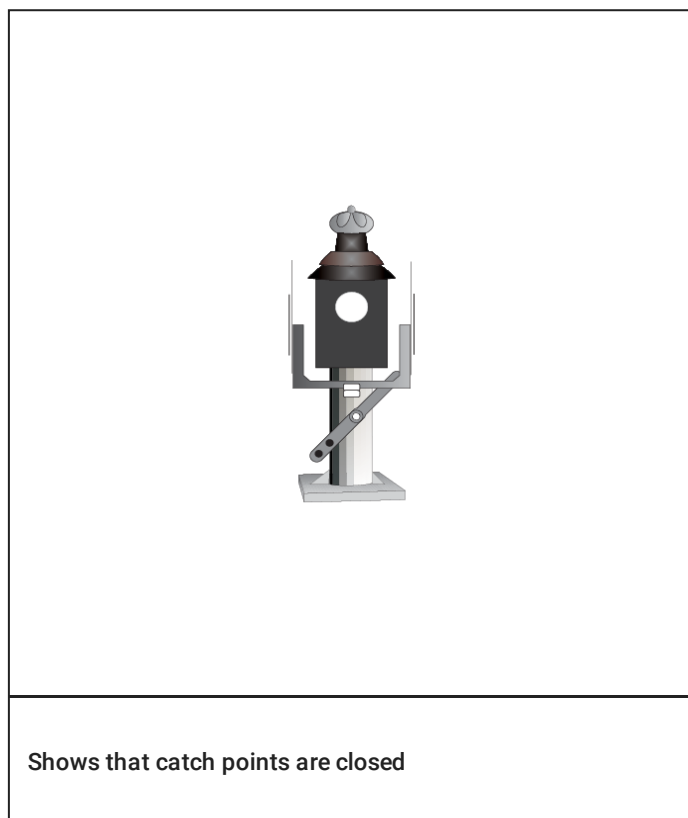
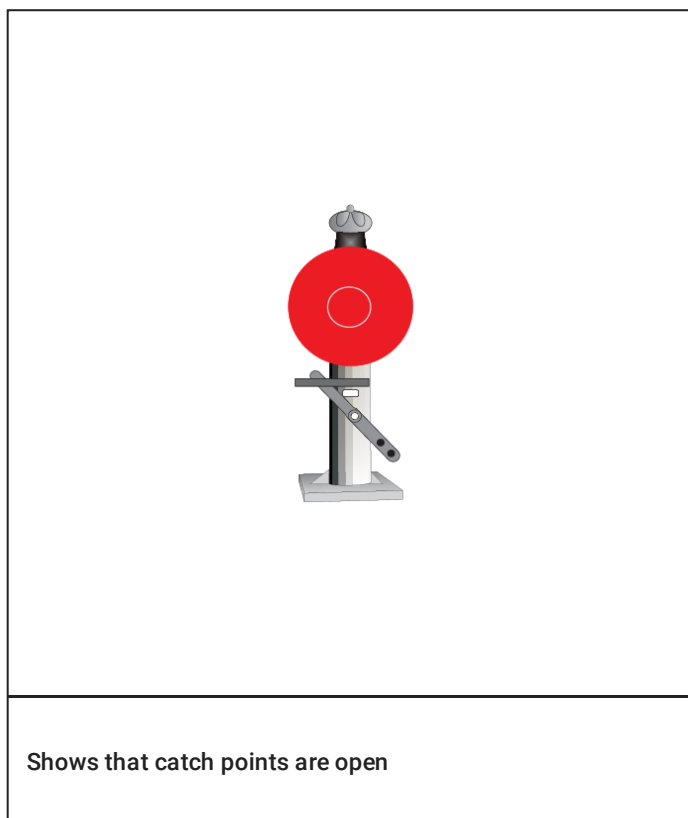

## NSG 604 Indicators and Signs

# Point and catch point indicators

FIGURE 8: Example of a mechanical point indicator shows points are set for the route indicated by the direction of the arrow.

